

# DELHI PUBLIC SCHOOL, JAMMU

Session (2021-22)

Holiday Homework

Class: X

SUBJECT-SCIENCE

## Physics

Perform an experiment on Ohm's law and prepare a project by pasting diagrams of electronic devices with their use in ohm's law circuit.

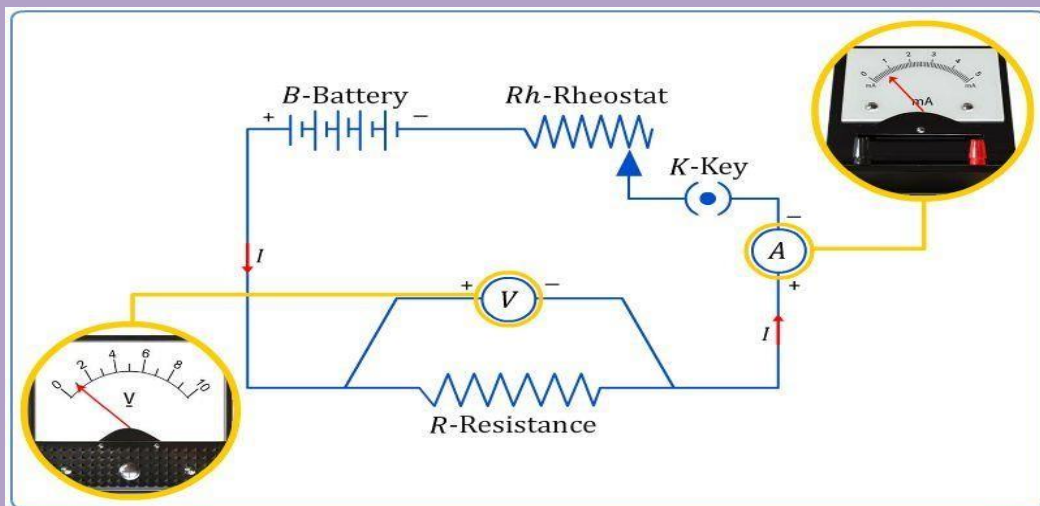

The project report should include:

1. Observations in Ohm's law

2. Connection of various devices in circuit.
3. Functions of all devices
4. Idea about linear and non-linear conductors

Link : <https://youtu.be/t0zXLxut7mc>

*Note: The Activity should be done manually and the project should be handwritten and done on a file with proper acknowledgement, certificate and bibliography.*

## Chemistry



**Perform an activity and make a project report on Corrosion in different types of metals (Iron, copper, silver and aluminium).**

The project report should include:

- 1.Observations at different intervals of time.
- 2.Samples collected before and after corrosion.
- 3.Definitions and reactions of metals due to corrosion.
- 4.Methods of prevention of corrosion.

Links : <https://www.youtube.com/watch?v=m8t4btjJd5Y>

*Note: The Activity should be done manually and the project should be handwritten and done on a file with proper acknowledgement, certificate and bibliography.*

# Biology

## BIOLOGY

**Q1.REPORT:** Make a report on human blood groups (with their characteristics).

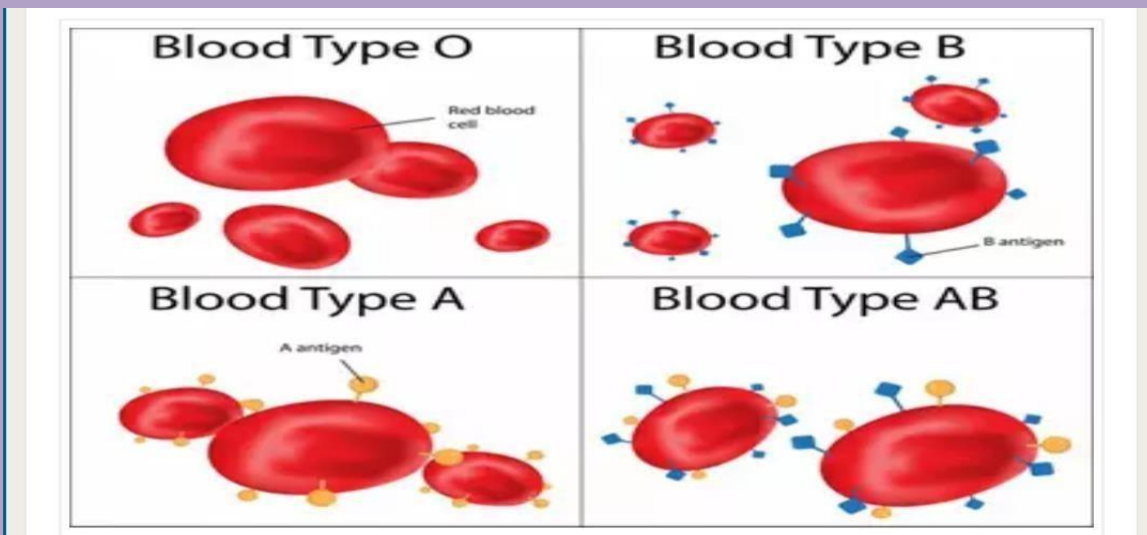

**Q2. ACTIVITY:** Write about 10 food items that increase our immunity and also mention how they do so.

[https://youtu.be/b\\_wxaHwJ0aM](https://youtu.be/b_wxaHwJ0aM)

**Q3.** Explain the structure of human heart. Also draw well labelled diagram.

**Q4.** Explain the mechanism of 'reflex action' in human body with suitable examples.

**Note -**

1. Send your Holiday Homework by e-mail to your respective Subject Teacher by 13th of July,2021. Your submission will carry 4 marks.( 2 marks- Subject Relevance & Research, 2 marks- Handwriting).

2. Practice for your Homework/ Project Presentation (5-6mins) to be held during virtual class after holidays. It will carry 6 marks.

(2 marks- Confidence, 2 marks- Subject Clarity, 2 marks- Presentation Skills).

3.The schedule for presentation will be shared later.

4.The teacher may ask 1 or 2 questions during the presentation.

- |   |       |
|---|-------|
| 1. Ms.Jasleen kour <a href="mailto:-Jasleenkour2792@gmail.com">-Jasleenkour2792@gmail.com</a>   | A,B,C |
| 2. Ms.Jyoti Jamwal- <a href="mailto:Jyotijamwal50@gmail.com">Jyotijamwal50@gmail.com</a>        | J     |
| 3. Ms.Bharti <a href="mailto:Munshi-bhartimunshi@gmail.com">Munshi-bhartimunshi@gmail.com</a>   | D,E,F |
| 4. Ms.Dipika <a href="mailto:sahni-deepshak.saini@gmail.com">sahni-deepshak.saini@gmail.com</a> | I     |
| 5. Mr.Prashant <a href="mailto:Verma-prashant.v85@gmail.com">Verma-prashant.v85@gmail.com</a>   | I     |
| 6. Ms. Pooja <a href="mailto:Chib-Poojachib5390@gmail.com">Chib-Poojachib5390@gmail.com</a>     | D,E,F |
| 7. Ms.Rekha <a href="mailto:Chib-Rekhachib49@gmail.com">Chib-Rekhachib49@gmail.com</a>          | A,B,C |
| 8. Mr.Satish <a href="mailto:Pawar-Satishpwr75@gmail.com">Pawar-Satishpwr75@gmail.com</a>       | F,G,H |
| 9. Mr.Mandeep <a href="mailto:Singh-mandy.7104@gmail.com">Singh-mandy.7104@gmail.com</a>        | D     |
| 10. Dr Gurmeet <a href="mailto:Kour-gurmeetabhi15@gmail.com">Kour-gurmeetabhi15@gmail.com</a>   | G,H   |
| 11.Dr Balbir <a href="mailto:Kour-balbirbalio2@gmail.com">Kour-balbirbalio2@gmail.com</a>       | I,J   |

12. Ms. Manika [Verma-manikaverma25@gmail.com](mailto:Verma-manikaverma25@gmail.com) E
13. Mr. Anil Dogra - [dpsanil77@gmail.com](mailto:dpsanil77@gmail.com) A,B,C
14. Tanvinder Kour: [tanvinderkour19@gmail.com](mailto:tanvinderkour19@gmail.com) G,H